

ENVIRONMENTAL PROPOSAL ACT



BRADBURY RIVER BRIDGE  
CONSTRUCTION PROJECT

Environment Act Proposal Form



Name of the development: Bradbury River Bridge	
Type of development per Classes of Development Regulation (Manitoba Regulation 164/88): Class 1 Concrete Batch Plant	
Legal name of the applicant: Greenfield Construction Ltd.	
Mailing address of the applicant: 209 General Manson Way, Miramichi N. B.	
Contact Person: Frank Flanagan	
City: Miramichi	Province: New Brunswick Postal Code: E1N 6K7
Phone Number: (506)627 - 6451	Fax: (506)622 - 7956 email: fflanagan@greenfield-construction.com
Location of the development: 30 Km north of Bloodvein on the Berens River All Season Road	
Contact Person: Frank Flanagan	
Street Address: 209 General Manson Way, Miramichi N. B.	
Legal Description: PR 304 To Berens River All Season Road Project	
City/Town: Miramichi	Province: New Brunswick Postal Code: E1N 6K7
Phone Number: 506 622 7900	Fax: 506 622 7900 email: fflanagan@greenfield-construction.com
Name of proponent contact person for purposes of the environmental assessment: Breanne Tozer	
Phone: (506)622 7900 Fax: (506)622 - 7956	Mailing address: 209 General Manson Way, Miramichi N. B. E1N 6K7
Email address: btozer@greenfield-construction.com	
Webpage address: www.greenfield-construction.com	
Date: 4 March 2016	Signature of proponent, or corporate principal of corporate proponent: <i>B Tozer</i> Printed name: Breanne Tozer

# **Environmental Act Proposal**

**Request:** License to Operate Mobile Concrete Batch Plant

**Project:** PR 304 Berens River All-Season Road Project

**Owner:** Manitoba East Side Road Authority

**Contract:** B7 Contract – Bradbury River Bridge

**Development Type:** Class 1

# Table of Contents

Executive Summary.....	2
1. Introduction and Background.....	3
2. Description of the Plant.....	3
2.1. Location of Land .....	3
2.2. Batching Operation .....	3
2.2.1. Wet-mix process .....	4
2.2.2. Dry-mix process .....	4
3. Description of Existing Environment in the Plant Area.....	4
3.1. Biophysical environment .....	4
3.1.1. Terrain features.....	4
3.1.2. Climate .....	4
3.1.3. Aquatic environment.....	5
3.1.4. Terrestrial environment.....	5
3.2. Socioeconomic environment.....	5
3.2.1. Public safety risk.....	5
3.2.2. Protected areas .....	5
3.2.3. Heritage resources.....	6
4. Description of Environment and Human Health Effects of the Plant .....	6
4.1. Batching materials.....	6
4.1.1. Aggregates .....	6
4.1.2. Cementitious materials.....	6
4.1.3. Admixtures.....	6
4.1.4. Water supply .....	6
4.2. Potential impacts of the plant on the environment .....	7
4.2.1. Impact on biophysical environment .....	7
4.2.2. Pollutants.....	7
4.2.3. Hazardous wastes .....	7
4.2.4. Storage of gasoline and associated products .....	7
4.2.5. Impact on heritage resources.....	7
4.2.6. Socioeconomic implications .....	7
4.3. Potential impacts of the plant on Human health and safety .....	7
5. Mitigation measures and Residual Environment Effects .....	8
5.1. Mitigation of dust emissions .....	8
5.1.1. Dust collection systems.....	8
5.1.2. Smooth flow.....	8
5.1.3. Additional measures.....	8
5.1.4. Use of water .....	8
5.2. Waste water handling.....	8
5.2.1. Concrete Washout Wastewater .....	8
5.2.2. Equipment Clean-down Water.....	9
5.3. Recycling returned concrete.....	9
5.4. Spillage Response .....	9
6. Follow-up, Monitoring & Reporting.....	9
6.1. Environmental guidelines.....	9
6.2. Preventive Maintenance Plan.....	9
7. Project Closeout .....	10
8. Conclusions.....	10
9. Appendices .....	10

# Executive Summary

Greenfield Construction's team has operated portable concrete products batch plants on several projects throughout the country

The plant has a daily processing capacity of approximately 50 cubic meters of concrete per hour.

The operation of the plant requires an Environmental License as the activities of batching are in Class 1 Development.

The report highlights the process of the BMH DEC50 concrete products batch plant and its impact on immediate environment.

In terms of impact to the environment, the main concerns are related to soil pollution, groundwater pollution, surface water pollution, air pollution, noise pollution, human health, and habitat destruction.

Mitigation measures are inherent in the DEC 50 to avoid the spread of contaminants into the environment.

The Environment Act Proposal concludes that the plant operates within acceptable environment limits.

Therefore, for this remote plant, Greenfield Construction is applying for the Environment Act License to the Manitoba Conservation and Water Stewardship by submitting an Environment Act Proposal.

# 1. Introduction and Background

Greenfield Construction's plant is a mobile ready mix concrete plant that will be certified by Manitoba Ready Mix Concrete Association.

The plant combines sand, aggregate (rocks and gravel), fly ash, cement, admixtures and/or water to form concrete. The pre-mix concrete produced is either wet or dry depending on the site requirements.

For the wet mix concrete, the product will be put into mixer trucks for delivery to the project site location within close proximity of the plant location.

Greenfield produces concrete product for our sole purposes and does not intend to produce product for retail to any other entity.

The facility utilizes the following equipment and accessories in the batching process:

- Cement silos
- Mixer, for blending the dry components of the concrete
- Cement weigh hopper
- Aggregate weigh hopper
- Aggregate bins
- Conveyors
- Batch plant controls
- Dust collectors
- Air compressor

## 2. Description of the Plant Location under this Application

### 2.1. Location

Plant will be set up in the rock quarry which is located on the east side of the road adjacent to the site of the new Bradbury Bridge.

It is described legally as;

SW 1/4 Sec 36 TWP 034 RGE 005 E1 (CQP Permit No. CP 2016-1008349)

### 2.2. Batching Operation

Greenfield will use the BMH DEC 50 mobile concrete batching plant. Equipment technical brochure attached (Appendix 1)

### **2.2.1. Wet-mix process**

Prior to commencement of batching, a ready mix truck is positioned under the loading chute.

For each batch, the requisite batch ingredients (cementitious, water, aggregates and admixtures) are weighed or metered in a given sequence controlled by the batch plant computer.

Cementitious material is discharged by auger and gravity in a controlled manner from the silos; sand and coarse aggregates are discharged from the weigh-bins along a conveyor. Water and admixtures are added to the truck load by volume metering.

Dust emitting from the truck area is controlled via fine tuning of the batching sequence to deliver a smooth, controlled flow of raw material into the mixer with a combination of water addition to control dust emissions.

Once all materials are in the truck's mixing drum, the revolution speed of the drum is increased to mixing speed for travel on roads to the project site.

### **2.2.2. Dry-mix process**

**(Process will not used on this application)**

While the plant can produce a dry mix for extended delivery it is not planned or required at this site.

## **3. Description of Existing Environment in the Plant Area**

### **3.1. Biophysical environment**

#### **3.1.1. Terrain features**

The facility is located beside the ESRA PR 304 road contract on the East side of the road at Stn 110+ 400 in an existing rock quarry. This location offers excellent containment properties in all respects. Bradbury River is approximately 150 meters North of the quarry site.

Other than the new road and bridge under construction there is no permanent or existing structures in the vicinity.

#### **3.1.2. Climate**

The prevailing climate and meteorological conditions of Bradbury River are marked by a subarctic climate, with long, bitterly cold winters, and short but warm summers. Monthly average temperatures range from minus 24.6 °C in January to plus 22.9 °C in July.

Though a majority of the annual precipitation of 370 millimeters falls from June to September, winter is by no means devoid of precipitation. Snow falls mainly from late October to May, totaling 140 centimeters per year. (Source: [the weather network.com](http://the.weather.network.com) )

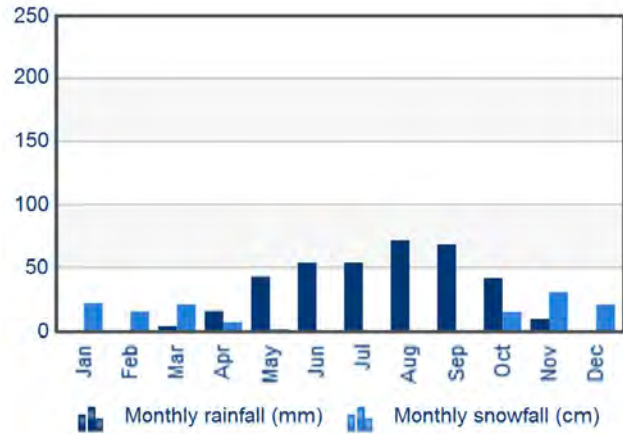
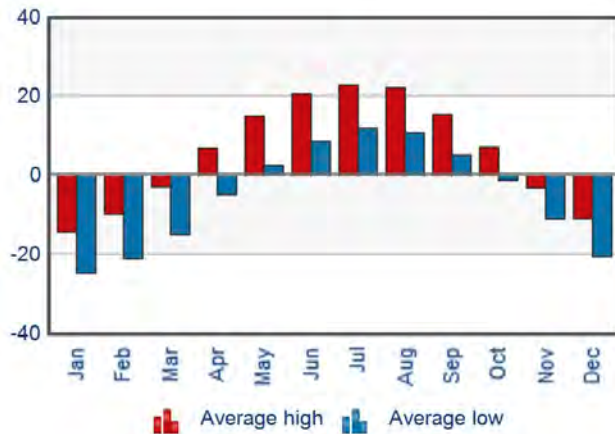

### 3.1.3. Aquatic environment

Regarding the aquatic environment, as the plant will be approximately 5m below grade in the quarry and there is no risk to the distant waterways

### 3.1.4. Terrestrial environment

The area is surrounded by thick trees and vegetation. However, in the surroundings of the facility, there is no presence of any rare, threatened or endangered species or any important or sensitive species and/or habitats. Again the chosen location acts as a natural shield to transmission of contaminants to the surrounding area.

## 3.2. Socioeconomic environment

### 3.2.1. Public safety risk

There is no public safety risk related to plant operations. The community of Bloodvein is approximately 30 km away.

### 3.2.2. Protected areas

There are no national and provincial protected parks in immediate area.

### 3.2.3. Heritage resources

There are no identified assets in the vicinity of the proposed plant.



## **4. Description of Environment and Human Health Effects of the Plant**

### **4.1. Batching materials**

#### **4.1.1. Aggregates**

Aggregates typically consisting of a single sand (5mm down) and a single gravel or crushed stone (10 mm to 20 mm max) are delivered to the yard by dump trailer trucks. The aggregates are stored in stockpile areas and storage bins at the plant. The amount on site at any one time will be in the magnitude of the requirements to manufacture 800 cubic meters of redi-mix concrete.

#### **4.1.2. Cementitious materials**

Portland cements types 2 and fly ash brought together to site combined and are stored in an elevated silo by bulk tanker trucks.

Each truck is equipped with an air blower system which enables it to blow the cement and fly ash mixture into the silo.

#### **4.1.3. Admixtures**

In order to impart particular properties to the concrete mixture, admixtures are used in the batching process. The mentioned admixtures are preloaded and housed in plastic tanks located in the auxiliary controls trailer admixtures supplier. Small plastic containers approved by the supplier are used for specialty mixes.

#### **4.1.4. Water supply**

Water for production will be drawn by submersible water pump from the Bradbury River. The inlet tube will have a screen to prevent biological or fish or other animal life from being drawn from the environment special care in selecting the optimal location within the waterway to further minimize distress to the environment will be done in consultation with a Fish Biologist professional.

Average anticipated daily use of water for this project will be 20,000 liters per day for a total of 15 pour days in 2 seasons of work.

The water is used for the following purposes:

- Mix water for batching concrete loads in the wet-process
- Filling truck-mounted water tank
- Dust suppression in the plant yard in high traffic areas
- Cleaning trucks and equipment in the marshalling area.

## **4.2. Potential impacts of the plant on the environment**

### **4.2.1. Impact on biophysical environment**

Due to the selected quarry location there is no impact of actual plant operations on wildlife, fisheries, surface water, groundwater, and forestry resources. Please see base map aerial photograph in attached documents.

### **4.2.2. Pollutants**

Major emissions come from dust particle emissions: the batching process generates dust

In addition, the operation can generate wastes in the form of excess concrete being brought back to the concrete batching plant within agitator trucks. In such case, all of this excess concrete is used to build precast concrete blocks used for construction barricades, formwork blocking and construction traffic control.

### **4.2.3. Hazardous wastes**

Any hazardous waste will be collected and transported to Winnipeg Landfill site according to their guidelines.

### **4.2.4. Storage of gasoline and associated products**

- Gasoline and diesel fuel will be stored in approved storage tanks
- Fuel for the equipment will be transported in an approved fuel truck.

### **4.2.5. Impact on heritage resources**

There is none.

### **4.2.6. Socioeconomic implications**

There are no socioeconomic implications resulting from environmental impact.

## **4.3. Potential impacts of the plant on Human health and safety**

There is no potential impact on human health and safety resulting from any release of pollutants from the plant.

## **5. Mitigation Measures and Residual Environment Effects**

### **5.1. Mitigation of dust emissions**

#### **5.1.1. Dust collection systems**

The plant is equipped with dust collection systems (in bagging and silos areas ) which have bag-houses used to control dust emissions from cement, fly ash and aggregates. These emissions occur when materials are loaded into silos, bins and hoppers. Dust collectors are inspected and cleaned on a monthly basis, and the fines are put back into the process.

The use of dust collection system mitigates any potential impacts of dust as air pollutant on the environment.

#### **5.1.2. Smooth flow**

Dust emitting from the truck area is controlled via fine tuning of the batching sequence to deliver a smooth and controlled flow of raw material into the mixer with a combination of water addition to control dust emissions.

#### **5.1.3. Additional Measures**

To further prevent dust from readily entering the surrounding environment a customized shroud is utilized in conjunction with the batching operation to further minimize unwanted transmissions.

#### **5.1.4. Use of water**

As said above, the water is used to mitigate dust impacts in the high traffic areas of the plant yard.

### **5.2. Waste Water / Washout Water Handling**

#### **5.2.1. Concrete Washout Water**

A concrete washout area will be created at the batch plant. This will typically be a metal bin sized appropriately to handle daily use. The sediment from the concrete residue is allowed to settle and then water mostly through evaporation is eliminated any further quantity is then poured through a filter cloth medium to further eliminate unwanted release. Concrete from this operation is then collected in purpose made bins and either broken down for use in clean fill or appropriate approved waste facility.

### **5.2.2 Equipment Clean-down Water**

Equipment will be installed on a gravel rock pad within the proposed quarry location a non-penetrable medium is specified below the crushed gravel waste and precipitation will shed from this medium to a purpose made tank where solids are allowed to settle and elements with buoyance can be skimmed from the top-water is then again pumped to filter through a cloth medium and will be used as a dust control on access or other construction areas in proximity. Sediments will be regularly collected from the bin and disposed of at an appropriate waste facility.

### **5.3. Recycling returned concrete**

Where operational and quality control restraints allow, any excess returned concrete is used to build precast as mentioned above.

Surplus material that cannot be used in this manor will be recycled to areas where clean fill is permitted.

### **5.4. Spillage Response**

In case of spillage, the plant responds according to the company spill response plan described in the spill containment procedure. (Appendix 3)

## **6. Follow-up, Monitoring & Reporting**

### **6.1. Environmental guidelines**

To ensure all environmental concerns, and precautions have been addressed and met, Greenfield's Mobile Plant Operation follows the "Recommended Guideline for Environmental Practices for Canadian Ready Mixed Concrete Industry."

### **6.2. Preventive Maintenance Plan**

Greenfield Construction has a comprehensive preventive maintenance program of its equipment. The program is performed through weekly checks that allow flexibility to react quickly to defect opportunities.

## **7. Project Close Out**

Unlike permanent installations and plant facilities this plant will have completed it's work within 1.5 years at this location, it will be dismantled and transported to the head office yard where it will be completely inspected and readied for the next project. Upon demobilization of the equipment the parcel will be returned to state as specified by Manitoba East Side Road Authority

## **8. Conclusions**

The EAP is completed in accordance with Manitoba Conservation's Advice for a Class 1 Development. The report has highlighted the process of Greenfield Construction's – BMH DEC 50 concrete products batch plant and its impact on immediate environment.

It has been demonstrated through this report that Greenfield Construction will operate with respect to its surrounding environment.

Therefore, specific equipment and processes are used since the facility exists to mitigate any environment issue from the plant operations.

To sum up, the report shows that the plant will operate within acceptable environment limits.

## **9. Appendices**

# **Appendix 1**

## **MDB DEC 50 Concrete Batch Plant Facility**

## MOBILE BATCH PLANTS

Whether for temporary installation, special projects or permanent facilities, the mobile concrete batch plants by BMH Systems provide an economical and reliable solution. These mobile plants have the advantage of being deployed in just a matter of days. Dry batch and central mix plants are available in a variety of aggregate and cement storage configurations and batch sizes. Whenever space limitations, fast set-up or easy moving are concerned, a BMH mobile batch plant is the optimal solution.

### CHARACTERISTICS :

- Low profile and high mobility batch plant
- Quick and easy set-up
- No foundation/erection required, blocking only
- Telescopic legs
- Heavy duty frame
- Factory wired, plumbed and tested



# DEC-50

Whether for a temporary installation, a special project or for a permanent facility, the mobile concrete batch plants by BMH Systems are designed for optimal performance. Our exclusive mobile plants need no concrete foundation and are ready for use in a snap.

Any load size can be processed from the scale-mounted aggregate hoppers and cement bin. This economical system makes no compromise on quality, versatility or performance.

All components used in our mobile plants are designed from the start to perform with outstanding results.



## SPECIFICATIONS DEC-50

Production capacity 65 yd<sup>3</sup> (50 m<sup>3</sup>) per hour

### FEATURES

- Low profile high mobility
- Decumulative batching
- Quick set up time
- No foundation/erection required, blocking only
- Telescopic legs
- Aggregate bin, 44 tons (40 metric tons), 2 compartments
- Direct front end loader charging of aggregates
- Cement bin, 33 tons (30 metric tons)
- Cement delivery: 2 screw conveyors, 10" (250 mm) diameter, 24'-0" (7,3 m) long, with 10 hp (7,5 kW) motors
- Transfer belt, 30" ribbed (760 mm)
- Electronic water meter, 2" (50 mm)
- Air compressor, 5 hp (3,7 kW)
- Air brakes, single axle, double wheels and fifth wheel
- Signal, brake and tail lights
- Factory wired and plumbed
- Factory tested



# **DEC-50**

## **AGGREGATE BIN**

- 20'-0" long (6,1 m)
- 8'-0" wide (2,4 m)
- 10'-3" high (3,1 m)

## **WEIGHING SYSTEM**

- 2 digital weigh indicators
- Cement bin mounted on 4 load cells of 25 000 lb each (11 400 kg)
- Aggregate bin mounted on 4 load cells of 25 000 lb each (11 400 kg)

## **WEIGHT**

- 32 000 lb (14 500 kg)

## **BATCHING CONTROL**

- Manual electric/air

## **ELECTRICAL POWER**

- Power panel, 460 or 575 Volts
- Other voltage available upon request

## **TRAVEL DIMENSIONS**

- 55'-4" long (16,9 m)
- 8'-6" wide (2,6 m)
- 14'-2" high (4,4 m)

## **OPTIONS**

- Cement bin extension, 11 tons (10 metric tons)
- 3 aggregates compartments with a total capacity of 44 tons (40 metric tons)
- Tandem axle, double wheel assembly
- Decumulative mobile cement bin, 33 tons (30 metric tons)
- Computerized batch control system
- Dust collector for cement bin
- Moisture probe
- Diesel generator power
- Cement bulk bag handling system

Compact technology,  
built for the road



MOBILE CONCRETE BATCH PLANT  
**DEC-50**  
DECUMULATIVE

# MOBILE CONCRETE BATCH PLANT

# DEC-50

MOBILE DECUMULATIVE CONCRETE BATCHING PLANT

The DEC-50 model is set to produce 65 yd<sup>3</sup> (50 m<sup>3</sup>) per hour of dry mix material. Its size, quality of construction, quick set-up and versatility provides you absolute mobility to any job site.

This decumulative mobile plant needs no concrete foundation and can be set-up and ready to use in a day. This is the perfect equipment for any contractor or job requiring batching concrete on-site.



## Innovative mobile plant

- Low profile and high mobility batch plant
- Quick and easy set-up
- No foundation required
- Telescopic legs
- Heavy duty frame

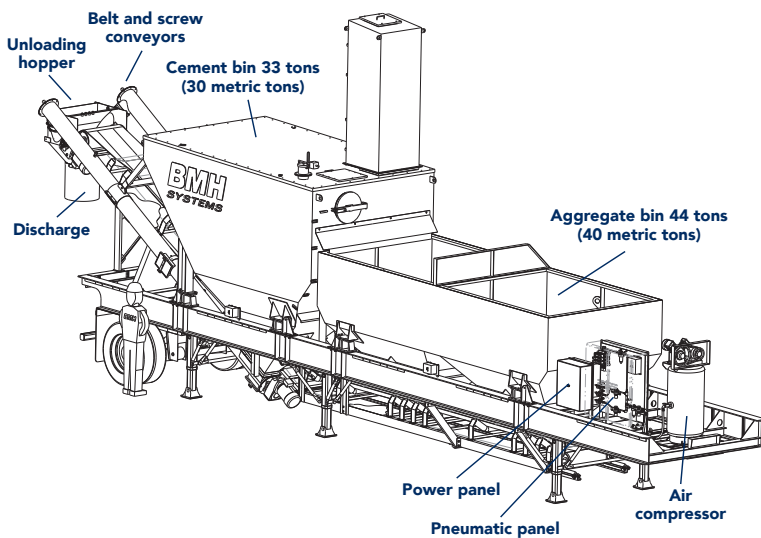

## Features

- Low profile high mobility
- Decumulative batching
- Quick set-up time
- No foundation/erection required, blocking only
- Telescopic legs
- Aggregate bin, 44 tons (40 metric tons), 2 compartments
- Direct front-end loader charging of aggregates
- Cement bin, 33 tons (30 metric tons)
- Cement delivery: 2 screw conveyors, 10" (250 mm) diameter, 24'-0" (7,3 m) long, with 10 hp (7,5 kW) motors
- Transfer belt, 30" (760 mm) ribbed with 10 hp (7,5 kW) motor
- Electronic water meter, 2" (50 mm)
- Air compressor, 5 hp (3,7 kW)
- Air brakes, single axle, double wheels and fifth wheel
- Signal, brake and tail lights
- Factory wired and piped
- Factory tested

## Batching Control

- Manual

## Weight

- 32 000 lb (14 500 kg)

## Electrical Power

- Power panel 460 or 575 volts
- Other voltage available upon request

## Travel Dimensions

- 55'-4" long (16,9 m)
- 8'-6" wide (2,6 m)
- 14'-2" high (4,4 m)

## Aggregate Bin

- 20'-0" long (6,1 m)
- 8'-0" wide (2,4 m)
- 10'-3" high (3,1 m)

## Options

- Cement bin extension, 11 tons (10 metric tons)
- 3 aggregates compartments with a total capacity of 44 tons (40 metric tons)
- Decumulative mobile cement bin, 33 tons (30 metric tons)
- Computerized batch control system
- Dust collector for cement bin
- Moisture probe
- Diesel generator
- Cement bulk bag handling system

# **Appendix 2**

## **Aerial View of Proposed Facility Location**

**ENVIROMENTAL ACT APPLICATION**  
**SW 1/4, SEC 36, TWP 34, RANGE 5E**

**Bradbury River**

150m

**PROPOSED  
BATCH PLANT LOCATION**



# **Appendix 3**

- 1. Enviromental Construction Operations Plan**
- 2. Form #008 Hazardous Material Spill Report**
- 3. Form #012 Site Hazard Assessment**
- 4. J.P. #002 Fueling of Equipment**
- 5. S.W.P. #032 Field Level Risk Assessment**

ENVIRONMENTAL  
CONSTRUCTION OPERATIONS  
PLAN



BRADBURY RIVER BRIDGE  
CONSTRUCTION PROJECT

# 1.0 Environmental Construction Operations Plan

## 1.1 Responsibilities

In addition to preparing the Environmental Construction Operations (ECO) Plan, GREENFIELD, as the contractor, has a number of responsibilities related to implementation and enforcement of the ECO Plan. These responsibilities include:

- Identifying an individual to be Greenfield's Site Representative to maintain environmental protection measures and identify environmental protection issues that arise during construction
- Ensuring staff and subcontractors are trained and empowered to identify, address and report environmental problems
- Implementing environmental protection measures in accordance with the ECO Plan
- Ensuring copies of applicable environmental documents (permits, etc.) are available at the work site
- Taking action to remediate deficiencies in environmental protection measures
- Taking appropriate action (e.g., shutting down work) when an environmental effect may occur
- Ensuring subcontractors comply with the ECO Plan
- Attending meetings or addressing concerns regarding the ECO Plan
- Monitoring the site to ensure the ECO Plan is effective for the conditions encountered, including weather events, or during shut-down periods
- Ensuring environmental incidents are reported and recorded as defined by the ECO Plan.

### Contractor Commitment

Greenfield Construction Ltd. is committed to providing quality products and services. Inherent to achieving this quality is the need to protect the environment and to mitigate environmental effects. GREENFIELD will abide by provincial and federal regulations and legal requirements to prevent impacts to the environment. Protection of the environment will be of the highest priority. As part of their commitment to environmental protection, GREENFIELD will follow this ECO Plan, and ensure that it is maintained and monitored for continual improvement in the future.

Signed: \_\_\_\_\_

  
President

Date: JAN 12, 2016



The construction site will be managed to minimize the area of disturbance and to reduce the off-site transport of sediments. This will be accomplished through staking of site boundaries for stripping footprints, and through the use of erosion and sediment control devices.

Exposed slopes and soil piles stored onsite during construction could be affected by erosion resulting from wind or rainfall. Movement of exposed soils to waterbodies and wetlands could result in sedimentation. This in turn may result in decreased water quality of naturally occurring waterbodies. Implementation of erosion and sediment control measures is required to mitigate these potential effects.

GREENFIELD will minimize the potential for erosion to occur, prior to resorting to sediment control measures. The areas within the site that have been identified as having high erosion potential will be monitored and measures installed as required.

The following mitigation measures are identified as possible alternatives to address erosion and sediment control:

- Silt Fence
- Erosion Control Matting
- Riprap ditches
- Rock Sediment Barriers
- Rehabilitation and Re-contouring
- Excavation and earth moving activities will be halted during high winds, when necessary

### *1.3 Dewatering Activities*

Ground water and surface water drainage and diversion activities shall be controlled in accordance with the approved Environmental Work Permit. Water diversion into sewer systems, drainage ways, and settling or polishing ponds shall require Project approval.

### *1.4 Equipment Maintenance*

Maintenance or use of construction equipment could result in spills during use or transfer of materials such as fuel, lubricants, hydraulic fluids, antifreeze or batteries. The following storage and management measures are designed to minimize the risk and potential effects of a spill or leak:

- Construction machinery will be well maintained and in good working condition prior to being brought onsite

- Construction machinery will be inspected and maintained to minimize the risk of breaks or leaks in lines and hoses
- All equipment entering and leaving the site should be free of excess grease
- Servicing and maintenance of machinery will occur at least 30 m from an environmentally sensitive area or waterbody
- Secondary containment such as an impervious tarp (i.e., polyethylene sheet) should be used to contain spills during the servicing or repair of equipment
- The construction site will be equipped with spill kits
- Operators will be trained in the use of spill containment equipment and spill clean-up
- Spills or incidents should be reported immediately to the GREENFIELD Site Representative, regulatory agencies where applicable.
- All spills (even when they are less than reportable volumes) will be recorded in Project documentation
- Spill containment and cleanup materials will be disposed of at an approved facility

Refueling of construction vehicles may be conducted through use of a mobile fuel truck. As refueling may occur throughout the site, additional measures are identified below to minimize the risks of fuel spills and leaks:

- Fuelling will not occur within 30 m of a water body or identified environmentally sensitive area.
- Vehicles will be refueled on a level surface (i.e., refueling on slopes, should be avoided)
- The fuel truck operator will be trained in containment and cleanup of spills
- The fuel truck will be equipped with appropriate absorbent materials and spill containment equipment

### 1.5 Waste Management

Mitigation measures for waste management are defined below:

- Incoming materials will be placed in materials storage areas until required for use
- Construction waste generated that is relatively small in size will be either placed in garbage containers or dumpsters
- Larger waste items will be stockpiled in a waste area and loaded and hauled to an approved waste disposal site as part of final cleanup.
- Hazardous waste will be stored in designated marked (placards or work site labels) containers; workers handling these products will be trained in the handling of the hazardous product and use of the identified PPE. A hazard assessment will be completed for handling of each hazardous substance.
- All opportunities to reuse, recycle or compost wastes (including asphalt, metal,

- batteries, vegetation, soils, etc.) will be explored and implemented
- The site will undergo a daily clean-up including removal of general litter and construction wastes
  - No waste and surplus excavation, rubble, rebar or metal will be stockpiled outside the working areas
  - The sanitary system will be cleaned and maintained on a regular basis
  - Spill clean-up materials will be disposed of in an approved facility
  - No rock, silt, cement, grout, lumber, vegetation, domestic waste, or any deleterious substance shall be placed or allowed to disperse into the site drainage system or water bodies
  - Concrete trucks will use designated concrete washout basins
  - Silt removed from sediment control structures will be removed and disposed of offsite or used in reclamation

Appropriate personal protective equipment must be available to staff handling hazardous wastes and materials, including gloves, protective suits, and goggles or face shields where required. Suitable emergency equipment, such as spill kits and appropriate fire extinguishers, must be available during storage and transport of hazardous waste materials.

### *1.6 Archaeological Sites*

Archaeological sites will be identified and flagged with “Caution” and “Do Not Enter” tape. Disturbing or removing archaeological sites is a criminal offence. As a result, any construction activities that expose archaeological sites shall require an immediate stoppage of work with referral to the Contractor Project EH&S Department for regulatory clearance.

### *1.7 Air Quality and Emissions*

Greenfield shall implement measures to prevent releases of any harmful substance to the atmosphere. Regular maintenance of mobile equipment and vehicles and watering of dusty roads will assist in improving air quality for personnel working in the construction area. Other initiatives will be implemented as needs are identified.

### *1.8 Wildlife Management*

Greenfield will utilize sound work planning, work practices and safe work procedures to minimize interaction with wildlife during construction. Fishing, hunting, trapping or feeding wildlife on site is prohibited. Disturbing or harming wildlife is regulated by legislation. Wildlife issues and concerns will be immediately reviewed with the Project Environmental Specialist. In addition, no pets are permitted on site or at the camp.

### 1.9 *Invasive Species Management*

Greenfield will conduct an impact assessment that includes invasive species mitigation prior to any work to be performed.

Invasive Alien species are species of plants, animals, and micro-organisms introduced by human action outside their natural past or present distribution. Invasive alien species are those harmful alien species whose introduction or spread threatens the environment, the economy, or society, including human health. Invasive alien species can originate from other continents, neighbouring countries, or from other ecosystems within Canada (Environment Canada, 2004).

According to the World Conservation Union, invasive alien species are the second most significant threat to biodiversity, after habitat loss. In their new ecosystems, invasive alien species become predators, competitors, parasites, hybridizers, and diseases of our native and domesticated plants and animals. The impact of invasive alien species on native ecosystems, habitats and species is severe and often irreversible.

Invasive plants are aggressively spreading, non-native species that have the potential to pose undesirable or detrimental impacts on humans, animals or ecosystems. Invasive plants have the capacity to establish quickly and easily on both disturbed and un-disturbed sites, and can cause widespread negative economic, social, and environmental impacts. Some species even pose serious human health risks.

#### ***Planning and Coordination***

- Inspect all sites for invasive plant presence before implementation of prescribed treatments.
- Identify Invasive Plants and Plan Maintenance Activities: Follow provincial guidelines, determine local problem plants, and contact your regional invasive species organization prior to planning maintenance activities.
- Consult invasive plant inventory and treatment maps as per area. Learn to identify invasive species and how to report them. Also, know how to identify native plants.
- Survey for invasive plants in all areas where planning site-disturbing activities.
- Conduct an impact assessment to record anticipated impacts. Treat all invasive plants in the project area before work begins.
- Eradicate invasive plant species before carrying out vegetation management treatments. Consider not applying treatments on areas where invasive plants are established and where plant density may increase as a result of the proposed management activity.
- Retain natural regeneration and understory vegetation in areas where management activities could affect the cover, density, and species composition of the native plant community.
- Include provisions for invasive plant prevention and ecosystem restoration in contracts and management plans that will result in soil and vegetation disturbance.

**General Procedures**

- Thoroughly clean equipment and machinery to remove seeds and vegetative plant material before moving to a new site.
- Carefully clean clothes, boots, hand tools, and other equipment used for treating invasive plants before leaving a site.
- Ensure road, trail or construction material (e.g. sand, gravel, fill, topsoil), originates from invasive plant-free pits or locations.
- Minimize unnecessary disturbance of roadside aggregates or soil, and retain desirable vegetation where possible
- Use only clean fill material from an “invasive plant free” source. Dispose of soil containing invasive plants in a Ministry approved spoil pile. Regularly inspect all material sources to ensure they are invasive plant free. Record and report invasive plant infested gravel pits and spoil piles.
- Reseed bare soil immediately after disturbance, and when soil surface, soil moisture, and weather conditions are suitable for germination and establishment.
- Avoid using straw or hay for erosion control unless the product can be certified invasive plant-free. Monitor sites where mulches, hay or straw applications protect the soil, and eradicate emerging invasive plants immediately.
- For disturbed areas, plan the composition of seed mixes to best suit each site. Composition may be entirely made up of native species if seed is available. Alternatively, non-invasive/non-persistent agronomic species can be used where their introduction does not interfere with management objectives. Use only Canada Certified Number 1 Grade seed where possible.
- Conduct invasive plant surveys for one and three years after completion of all projects that create disturbance or implement restoration treatments.
- Record and Report Invasive Plants: Ensure invasive plants are recorded and reported. Call your regional invasive species organization
- Keep Equipment Clean: Avoid parking, turning around, or staging equipment in invasive plant infested areas; or mow the areas prior to use. Wash equipment after returning it to the maintenance yard. Inspect and clean vehicles before entering a weed free area, and before leaving an infested area.

**Seed Analysis Procedures**

Undesirable plants can be introduced through contaminants in seed mixtures! Typically labels on a bag of seed only show the main species in the mix. Contaminants are not listed! Therefore you need to

- Request the Certificate of Seed Analysis for each lot of each species in your mix prior to purchasing and blending the seed.
- Check the Certificates of Seed Analysis for any undesirable species, especially invasive plants and noxious weeds!
- Reject or approve the seed based on what is found, and discuss with supplier.
- Report any seed lots that contain weeds or species of potential concern.

When reviewing the Certificates of Seed Analysis, check for:

1. Date completed.
2. Species listed under “Other Crop Seeds”, “Other weed seeds” or “Noxious Weeds”.
3. Signature and stamp from an accredited seed testing laboratory

1.10 Potential Emergencies and Response Procedures

Emergency	Response Procedure	Emergency Contacts
<p>Substance spill or release</p> <p>Example: A diesel spill from the fuel truck</p>	<p><b>Initial Response:</b> Secure the spill or release (if it is safe to do so)</p> <ul style="list-style-type: none"> <li>• Notify the Site Supervisor.</li> <li>• If safe to do so, contain the spill or release with spill kit materials, such as absorbent materials or booms, dykes, or liners.</li> <li>• If the spill has occurred during transport, contact the Department of Transport or CANUTEC.</li> </ul> <p><b>Mitigation:</b></p> <ul style="list-style-type: none"> <li>• Ensure machinery is in good working condition.</li> <li>• Ensure materials and wastes are stored in designated areas within the construction site.</li> <li>• Ensure employees using hazardous goods are properly trained and equipped to do so.</li> <li>• Ensure spill kits are available onsite.</li> <li>• Use a drip tray when refuelling construction machinery when required to do so by regulations.</li> <li>• Replenish spill kit materials if they have been used.</li> <li>• Review potential hazards at safety and tailgate meetings.</li> <li>• Review emergencies and incidents to improve handling and response procedures.</li> </ul>	<p>GREENFIELD Site Supervisor:</p> <p>GREENFIELD Safety and Environment Coordinator:</p> <p>CANUTEC (Emergency) 613-996-6666 Or *666 (cellular only)</p>
<p>Extreme weather event</p> <p>Example: Heavy rain resulting in slope erosion</p>	<p><b>Initial Response:</b></p> <ul style="list-style-type: none"> <li>• Stop work immediately.</li> <li>• Notify the Site Supervisor of flooding or increasing erosion that may result in failure or damage to erosion and sediment control measures.</li> <li>• If it is safe to do so, mitigate flooding and erosion to prevent or reduce sediment release resulting from failing erosion and sediment control measures.</li> <li>• Inspect erosion and sediment control measures.</li> <li>• Resume work only if safe to do so.</li> </ul> <p><b>Mitigation:</b></p> <ul style="list-style-type: none"> <li>• Inspect erosion and sediment control measures regularly to ensure they are well maintained and in good condition.</li> <li>• Replace or repair erosion and sediment control measures as needed.</li> <li>• Secure slopes and spoil piles if extreme weather is imminent.</li> <li>• Review potential hazards at safety and tailgate meetings.</li> <li>• Review emergencies and incidents to improve handling and response procedures.</li> </ul>	<p>GREENFIELD Site Supervisor:</p> <p>GREENFIELD Safety and Environment Coordinator:</p>

<p>Wildlife encounter</p> <p>Example: A bear is attracted to the site</p>	<p><b>Initial Response:</b></p> <ul style="list-style-type: none"> <li>• Stop work immediately in the vicinity of the wildlife sighting.</li> <li>• Notify the Site Supervisor of the presence of wildlife on the site.</li> <li>• Attempt to deter the animal with loud noise or shouting.</li> <li>• Do not approach the animal.</li> <li>• Resume work in the area only once the animal has left the site.</li> </ul> <p><b>Mitigation:</b></p> <ul style="list-style-type: none"> <li>• Maintain the site in good condition, and clean up garbage daily to reduce attractants.</li> <li>• Secure fluids, oils, gasoline, diesel or other materials nightly prior to leaving site to prevent animals from accessing them.</li> <li>• Ensure areas are well lit if work is being conducted in dawn or dusk hours.</li> <li>• Review potential hazards at safety and tailgate meetings.</li> <li>• Ensure employees, and Department of Environment and Natural Resources where applicable, are aware of recurring wildlife encounters as this may indicate presence of an habituated animal in the vicinity of the construction site.</li> <li>• Review emergencies and incidents to improve handling and response procedures.</li> </ul>	<p>GREENFIELD Site Supervisor:</p>           <p>GREENFIELD Safety and Environment Coordinator:</p>
<p>Fire</p> <p>Example: A fire is started in the woody debris waste pile</p>	<p><b>Initial Response:</b></p> <ul style="list-style-type: none"> <li>• Stop work immediately and evacuate the area around the fire.</li> <li>• If it is safe to do so, attempt to extinguish the fire with an appropriate fire extinguisher (pressurized extinguisher for Class A fires; ABC, BC or CO<sub>2</sub> units for Class B fires).</li> <li>• Notify the Site Supervisor immediately.</li> <li>• For wildfires, contact the provincial emergency wildfire reporting line.</li> </ul> <p><b>Mitigation:</b></p> <ul style="list-style-type: none"> <li>• Store materials and waste in appropriate locations within the site.</li> <li>• Ensure flammable materials are correctly stored away from open flames.</li> <li>• Do not allow smoking while conducting refuelling activities or using flammable materials.</li> <li>• Have a designated smoking area away from vegetation and ensure cigarette butts are correctly extinguished.</li> <li>• Avoid using machinery in vegetated areas if the fire hazard has been rated as medium or higher.</li> <li>• Review potential hazards at safety and tailgate meetings.</li> <li>• Review emergencies and incidents to improve handling and response procedures.</li> </ul>	<p>GREENFIELD Site Supervisor:</p>           <p>GREENFIELD Safety and Environment Coordinator:</p>



### *1.11 Documentation*

Documentation onsite will include the following:

- applicable environmental permits and approvals
- daily work reports
- weekly work summaries
- field level risk assessments
- tool box safety talks
- correspondence with the client and the consultants representing the client
- meeting minutes
- spill reports



# FORM #008 HAZARDOUS MATERIAL SPILL REPORT

REVISION 2  
DATE: JAN 2014

This form must be completed and filled in case of a hazardous material spill. All hazardous material spills must be immediately reported to the Environmental Department in order to minimize and/or eliminate risk of contamination.

\_\_\_\_\_ Date of Spill \_\_\_\_\_ Approx. Time \_\_\_\_\_ Division / By Whom \_\_\_\_\_

\_\_\_\_\_ Date Reported \_\_\_\_\_ Location \_\_\_\_\_ Reported By \_\_\_\_\_

\_\_\_\_\_ Material \_\_\_\_\_ Quantity \_\_\_\_\_

Direct / Indirect Cause:

\_\_\_\_\_  
\_\_\_\_\_  
\_\_\_\_\_

Spill:  Terminated  Continuing  Containment Required

Injuries / Exposure:

Y  N

Coast Guard Notified:

Y  N

Corrective Actions:

\_\_\_\_\_  
\_\_\_\_\_  
\_\_\_\_\_

Assistance Required? Manpower and equipment involved:

\_\_\_\_\_  
\_\_\_\_\_

\_\_\_\_\_ Environmental Supervisor / Technician Signature \_\_\_\_\_ Date \_\_\_\_\_

\_\_\_\_\_ Senior Management Signature \_\_\_\_\_ Date \_\_\_\_\_

The purpose of this site hazard assessment form is to determine potential hazards that may be present at project sites. It must be performed at all new project sites or when unusual tasks are involved. This assessment must be completed by the Company Safety Supervisor, Site Supervisor and a member of the Joint Health & Safety Committee or a Safety Representative. Observations must be reviewed and corrective actions must be documented.

Project Site:	Date:
---------------	-------

**ASSESSMENT TEAM**

Name	Position	Signature

**SECTION 1:** Review the job plan and list all the tasks involved. The list should be developed from the annual assessment.

Task	Hazards	Controls	HP

Hazard Priority Ranking is as follows:

- |  |  |  |   |
|--|--|--|---|
| <b>1. Catastrophic</b><br>A) Probable<br>B) Reasonable<br>C) Remote<br>D) Unlikely | <b>2. Critical</b><br>A) Probable<br>B) Reasonable<br>C) Remote<br>D) Unlikely | <b>3. Marginal</b><br>A) Probable<br>B) Reasonable<br>C) Remote<br>D) Unlikely | <b>4. Minor</b><br>A) Probable<br>B) Reasonable<br>C) Remote<br>D) Unlikely |
|--|--|--|---|

**SECTION 2:** Please check "OK" or place a letter in the "Action Req." box if the item is not up to standard. Give a brief description of the action required in the notes area below this table.

ITEM	OK	ACTION
<b>Training</b>	-----	-----
1. Worker	-----	-----
2. Supervisor	-----	-----
3. Other _____	-----	-----
<b>First Aid / Emergency</b>	-----	-----
1. Supplies	-----	-----
Adequate Supplies	-----	-----
Record Form	-----	-----
Regulation 2004-130 Available	-----	-----
2. Adequate No. of Personnel	-----	-----
Names Posted	-----	-----
3. Emergency No. Posted	-----	-----
4. Communication	-----	-----
5. Emergency Procedures	-----	-----
6. Fire Extinguishers	-----	-----
7. W.H.M.I.S.	-----	-----
M.S.D.S Available	-----	-----
Regulations Available	-----	-----
8. Rescue	-----	-----
<b>Equipment</b>	-----	-----
1. Mobile Equipment	-----	-----
2. Vehicles	-----	-----
3. Floats / Trailers	-----	-----
4. Seat Belts	-----	-----
5. Power / Hand Tools	-----	-----
6. Extension Cords	-----	-----
7. Ladders / Scaffolding	-----	-----
8. Slings / Rigging / Hoisting	-----	-----
9. Cranes	-----	-----
10. Lock out	-----	-----
<b>Site Office</b>	-----	-----
1. Access / Egress	-----	-----
2. Lighting	-----	-----
3. Ventilation	-----	-----
4. Heating	-----	-----
5. Sanitation and Accommodations	-----	-----
<b>Grounds / Structures</b>	-----	-----
1. Storage	-----	-----
2. Drainage	-----	-----
3. Soil Condition	-----	-----
4. Underground installations	-----	-----
5. Lighting	-----	-----
6. Visibility	-----	-----
7. Traffic Control / Rules	-----	-----
8. Parking	-----	-----
9. Public Access	-----	-----
10. Working @ Heights	-----	-----
11. Fall Protection	-----	-----
12. Access / Egress	-----	-----
<b>Electricity</b>	-----	-----
1. Overhead Lines	-----	-----
2. Underground Installations	-----	-----
3. Transformers	-----	-----
4. Temporary Installations	-----	-----

**Notes:**

---

---

---

---

---

---

---

---

---

---

---

---

---

---

---

---

---

---

---

---

---

---

---

**Safety Supervisor:** \_\_\_\_\_

**Date:** \_\_\_\_\_

**Project Manager:** \_\_\_\_\_

**Date:** \_\_\_\_\_

***Personal Protective Equipment***

- Hardhat
- Safety Boots
- Gloves
- Eye Protection

***Procedure***

1. Shut off machine/vehicle and remove fuel cover.
2. Turn on fuel pump.
3. Do not smoke while fueling machine.
4. Remove fuel cover and put filter nozzle in filler neck. Be sure to ground the filler nozzle against the filler neck to prevent spills.
5. Never leave nozzle unattended when fueling. Up kick out could fail and fuel will spill.
6. When fuel is 2 inched below the filler neck remove nozzle, shut fuel and hang up nozzle. Be sure to pick up the hose.
7. Replace fuel cover and wipe any excess fuel off machine.

**N.B.** \* The information presented in this publication is intended for general use and may not apply to every circumstance. It is not a definitive guide to government regulations and does not relieve persons using this publication from their responsibilities under applicable legislation.

***Purpose***

To educate workers and protect and the environment during company projects requiring the use of flammable products.

***Selection and Use***

As per job requirement

***Supervisor Responsibility***

- Ensure that workers are properly trained in the safe handling, use, storage or disposal of flammable or combustible substances while on and off site.
- Ensure that workers are provided with adequate information concerning the identity, nature, and potential hazards of the substance
- Ensure that a hazardous substance is stored so as to protect the health and safety of employees, using information available on a material safety data sheet or obtained from the supplier or another reliable source.

***Worker Responsibility***

1. In the event of contamination of flammable material; stop all activities that may cause a spark and avoid open flames, cautiously remove contaminated clothing and start the process of decontamination, wash off your skin with water immediately and seek first aid. You could become a human torch
2. Do not store flammable materials such as gasoline in the wrong kind of container. Sometimes glass containers are used to hold this liquid, if you have a glass jar stored in your car and hit a bump on the road, the jar could break and the vapors could ignite.
3. Keep gasoline in an approved safety can (CSA B376 M1980 (R2008), Portable Containers for Gasoline and Other Petroleum Fuels. Mark the container with the word "Gasoline" so that people will not mistake it for something else.
4. Store Flammable liquids in areas and quantities that will not endanger workers if they are inadvertently released or spilled.
5. Ensure any substance that may react with another substance is stored separately from such other substances
6. Transfer flammable materials from one container to the other only in areas free from open flames, sparks, and where there is proper ventilation.
7. Clean up any spill immediately. Follow environmental procedures.

**N.B.** \* The information presented in this publication is intended for general use and may not apply to every circumstance. It is not a definitive guide to government regulations and does not relieve persons using this publication from their responsibilities under applicable legislation.

Check off the hazards that apply to this job. List the item # in the 2nd column (other side). Identify the plans to eliminate or control them in the 3rd column (other side).

<b>Environmental Hazards</b> 1. Work area clean <input type="checkbox"/> 2. Material storage identified <input type="checkbox"/> 3. Dust / Mist / Fume <input type="checkbox"/> 4. Noise in area <input type="checkbox"/> 5. Extreme temperatures <input type="checkbox"/> 6. Spill potential <input type="checkbox"/> 7. Waste containers needed <input type="checkbox"/> 8. Waste properly disposed <input type="checkbox"/> 9. Waste plan identified <input type="checkbox"/> 10. Excavation permit required <input type="checkbox"/> 11. Other workers in area <input type="checkbox"/> 12. Weather conditions <input type="checkbox"/> 13. MSDS reviewed <input type="checkbox"/>	<b>Access / Egress Hazards</b> 23. Aerial lift / Man basket (Inspected & tagged) <input type="checkbox"/> 24. Scaffold (Inspected & tagged) <input type="checkbox"/> 25. Ladders (tied off) <input type="checkbox"/> 26. Slips / Trips <input type="checkbox"/> 27. Hoisting (tools, equipment) <input type="checkbox"/> 28. Excavation (alarms, routes, ph. #) <input type="checkbox"/> 29. Confined space entry permit required <input type="checkbox"/>	<b>Rigging &amp; Hoisting Hazards</b> 38. Lift study required <input type="checkbox"/> 39. Proper tools used <input type="checkbox"/> 40. Tools inspected <input type="checkbox"/> 41. Equipment inspected <input type="checkbox"/> 42. Slings inspected <input type="checkbox"/> 43. Others working overhead / below <input type="checkbox"/> 44. Critical lift permit <input type="checkbox"/>
<b>Ergonomic Hazards</b> 14. Awkward body position <input type="checkbox"/> 15. Over extension <input type="checkbox"/> 16. Prolonged twisting bending motion <input type="checkbox"/> 17. Working in a tight area <input type="checkbox"/> 18. Lift too heavy / Awkward to lift <input type="checkbox"/> 19. Parts of body in line of fire <input type="checkbox"/> 20. Repetitive motion <input type="checkbox"/> 21. Hands not in line of sight <input type="checkbox"/> 22. Working above your head <input type="checkbox"/>		<b>Electrical Hazards</b> 45. GFI test <input type="checkbox"/> 46. Lighting levels too low <input type="checkbox"/> 47. Working on/near energized equipment <input type="checkbox"/> 48. Electrical cords condition <input type="checkbox"/> 49. Electrical tools condition <input type="checkbox"/> 50. Fire extinguisher <input type="checkbox"/> 51. Hot work or electrical permit required <input type="checkbox"/>
	<b>Overhead Hazards</b> 30. Barricades & Signs in place <input type="checkbox"/> 31. Hole coverings identified <input type="checkbox"/> 32. Harness / Lanyard inspected <input type="checkbox"/> 33. 100% Tie-off w/harness <input type="checkbox"/> 34. Tie off points identified <input type="checkbox"/> 35. Falling items <input type="checkbox"/> 36. Foreign bodies in eyes <input type="checkbox"/> 37. Hoisting or moving loads overhead <input type="checkbox"/>	<b>Personal Limitations / Hazards</b> 52. Procedure not available for task <input type="checkbox"/> 53. Confusing instructions <input type="checkbox"/> 54. No training for task or tools to be used <input type="checkbox"/> 55. First time performing the task <input type="checkbox"/> 56. Micro Break (stretching / flexing) <input type="checkbox"/> 57. Report all injuries to your supervisor <input type="checkbox"/>

It is important that all hazards have plans to eliminate them and the plans are put in place. Ensure that all associated permits are closed off at the end of the job.

**Remember: "Stop & Think" & "See It Again For The First Time".**

Work to be done:	Date:
Task location:	Emergency meeting location:
	Permit Job #

Identify and Prioritize the tasks and hazards below, then identify the plans to eliminate/control the hazards.

TASKS	HAZARDS	PLANS TO ELIMINATE/CONTROL
		

Require Gloves to be Removed Yes <input type="checkbox"/> No <input type="checkbox"/>	Warning ribbon needed? Yes <input type="checkbox"/> No <input type="checkbox"/>
Is the worker working alone? Yes <input type="checkbox"/> No <input type="checkbox"/>	If Yes, explain
<b>Job Completion</b>	
Are all Permit(s) closed out? Yes <input type="checkbox"/> No <input type="checkbox"/>	Are there Hazards remaining? Yes <input type="checkbox"/> No <input type="checkbox"/> (If Yes, explain)
Was the area cleaned up at end of job / shift? Yes <input type="checkbox"/> No <input type="checkbox"/>	
Were there any incident / injuries? Yes <input type="checkbox"/> No <input type="checkbox"/>	If Yes, explain

Please print and sign below (All members of the crew) prior to commencing work and initial when task is completed or at the end of the shift

Worker Name and Signature (below) \_\_\_\_\_ Foreperson's Name & Signature: \_\_\_\_\_  
(sign upon reviewing completed card)

All Names and Signatures should be legible Reviewed by Name & Signature: \_\_\_\_\_